

b64
AIRLOCK



Quick Start Guide

bernette
SWISS DESIGN

IMPORTANT SAFETY INSTRUCTIONS

Please be aware of the following basic safety instructions when using your machine. Before using this machine, read instruction manual carefully.

DANGER!

To reduce the risk of electrical shock:

- Never leave the machine unattended as long as it is plugged in.
- Always unplug the machine from the electrical outlet after using and before cleaning.

Protection against LED radiation:

- Do not view the LED light directly with optical instruments (e.g. magnifier). The LED light corresponds with protection class 1M.
- When the LED light is damaged or defective, contact your bernette specialist dealer.

WARNING

To reduce the risk of burns, fire, electric shock or injury to persons:

- To operate the machine always use the supplied power cable. USA and Canada only: Do not connect power plug NEMA 1-15 to circuits exceeding 150 volt-to-ground.
- This machine may only be used for the purpose described in this instruction manual.
- Only use the machine in dry rooms.
- Do not use the machine in a damp condition or in a damp environment.
- Do not use the machine as a toy. You must take extra care if the machine is being used by children or in the vicinity of children.
- This machine may be used by children eight years of age and older as well as persons with restricted physical, sensory or mental capacities or lack of experience and knowledge under supervision or having received instruction on the safe use of the machine and the resulting hazards. Children must not play with the machine.
- Cleaning and maintenance work must not be carried out by children without supervision.
- Do not use this machine if the cable or plug is damaged, the machine is not functioning correctly, it is dropped or becomes damaged or falls in water. Return the machine to your local authorized bernette dealer for examination or repair.
- Only use accessories recommended by the manufacturer.
- Do not use this machine if the ventilation openings are blocked. Keep all ventilation openings and foot control free of lint, dust and loose cloth.
- Do not insert any objects into the openings of the machine.
- Do not place any objects on the foot control.
- Always use the machine with a foot control of this type 4C-316/-326/-345.
- Do not use the machine anywhere that oxygen or propellant products (sprays) are being used.
- The knife cover insert or coverstitch insert must be attached continuously while operating the machine.
- Keep fingers away from all rotating and moving parts. Special care is required in the needle area, the looper and the knife.
- Neither pull nor push the fabric while sewing. This can cause needle breakage.

- Turn power switch to «0» when making any adjustments in the needle area, such as threading the needle or changing the needle or the presser foot.
- Never use damaged needles.
- Always use the original bernette stitch plate. The wrong stitch plate can cause needle breakage.
- To disconnect, turn power switch to "0" and then remove the plug from the outlet. Always pull on the plug and not the cable.
- Disconnect the plug before removing or opening the covers, oiling the machine or performing any cleaning or maintenance work described in this instruction manual.
- This machine is double-insulated (except for USA, Canada and Japan). Use only genuine replacement parts. See instructions for Servicing of double-insulated products.

Important information

Availability of the instruction manual

The short manual is part of the machine.

- Keep the short manual of the machine in a suitable place near the machine and have it ready for reference.
- A detailed instruction manual can be downloaded from **www.bernette.com**.
- When passing on the machine to a third party, enclose the short manual of the machine.

Proper use

Your bernette machine is conceived and designed for private household use. It is intended for sewing fabrics and other materials as described in this instruction manual. Any other use is not considered appropriate. BERNINA assumes no liability concerning consequences resulting from an inappropriate usage.

Maintenance of double-insulated products

In a double-insulated product, two systems of insulation are provided instead of grounding. No grounding means is provided on a double-insulated product nor should a means for grounded be added to the product. Servicing a double-insulated product requires extreme care and knowledge of the system and should only be done by qualified service personnel. Only original spare parts should be used for service and repairs. A double-insulated product is marked with the words: «Double-Insulation» or «double-insulated».

 The symbol  may also be marked on the product.

Environmental Protection



bernette is committed to environmental protection. We strive to minimize the environmental impact of our products by continuously improving product design and our technology of manufacturing.

The machine is labeled with the symbol of the crossed-out wastebbin. This means that the machine must not be disposed of with the household waste when the machine is no longer needed. Improper disposal can result in dangerous substances getting into the groundwater and thus into our food chain, damaging our health.

The machine must be returned free of charge to a nearby collection point for waste electrical and electronic equipment or to a collection point for the reuse of the machine. Information on the collection points can be obtained from your local administration. When purchasing a new machine, the dealer is obliged to take back the old machine free of charge and dispose of it properly.

If the machine contains personal data, you are responsible for deleting the data yourself before returning the machine.

Content

Details of machine	1
Connection and switching on	2
Changing the needle	2
Changing the presser foot	2
Threading the looper threads.....	3
Threading the needle threads.....	6
Adjusting the thread tensions	8
Setting the mtc micro thread control.....	8
Setting the cutting width	
Setting the stitch length	
Adjusting the differential feed	
Cleaning and maintenance	
Troubleshooting.....	13

Details of machine



- | | | | |
|---|---------------------------------|----|-------------------------------|
| 1 | Presser foot lifter | 7 | Rolled hem selection lever |
| 2 | Stitch length | 8 | mtc micro thread control dial |
| 3 | Differential feed | 9 | Cutting width |
| 4 | Handwheel | 10 | Presser foot pressure |
| 5 | Foot control-/ power connection | 11 | Thread cutter |
| 6 | Power switch | 12 | Presser foot lifter |

Connection and switching on

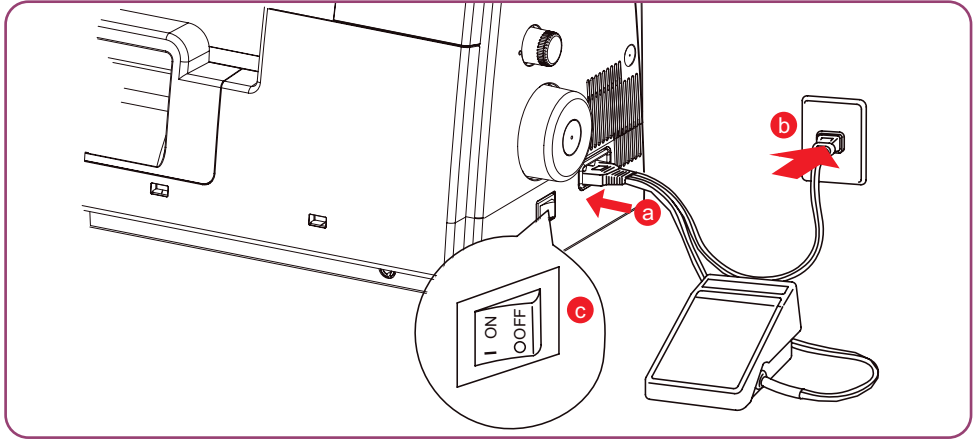

Changing the needle

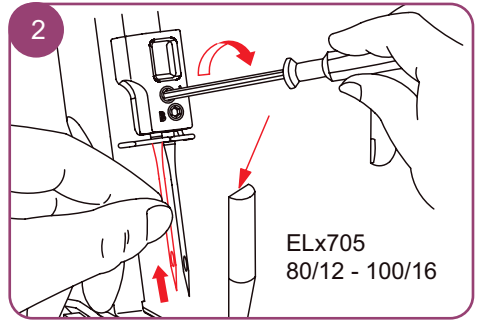
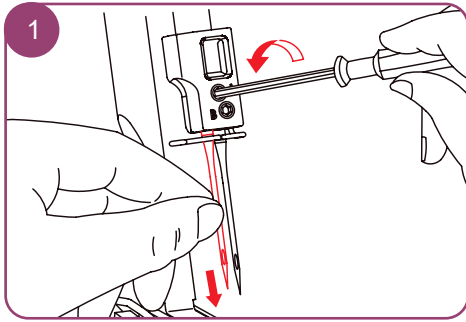

Changing the presser foot

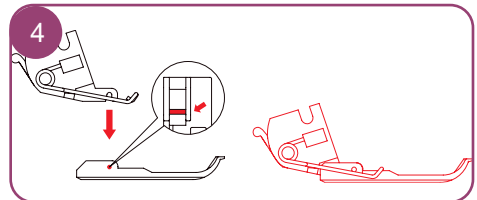
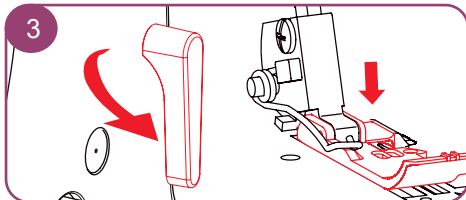
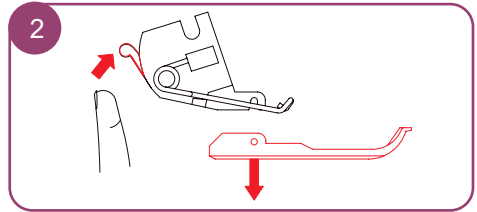
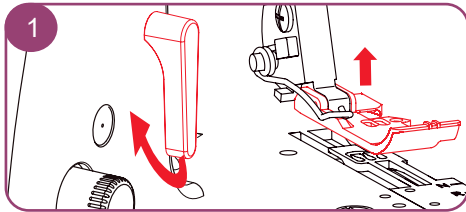

Threading the looper threads

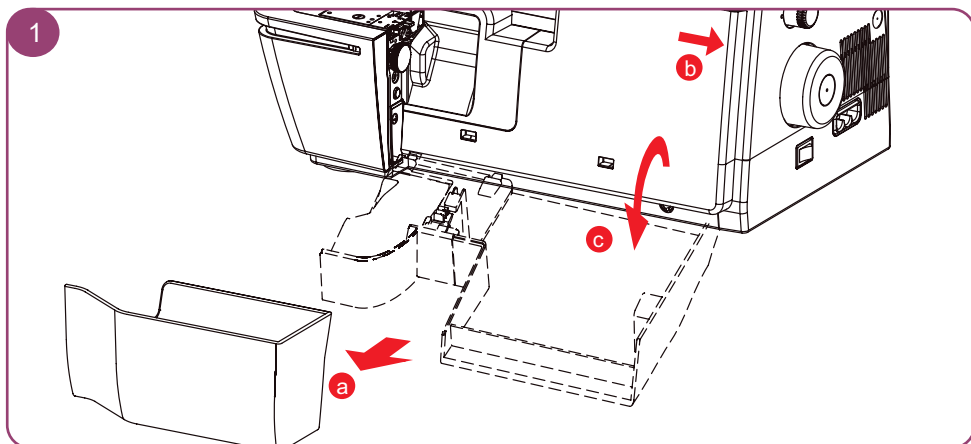

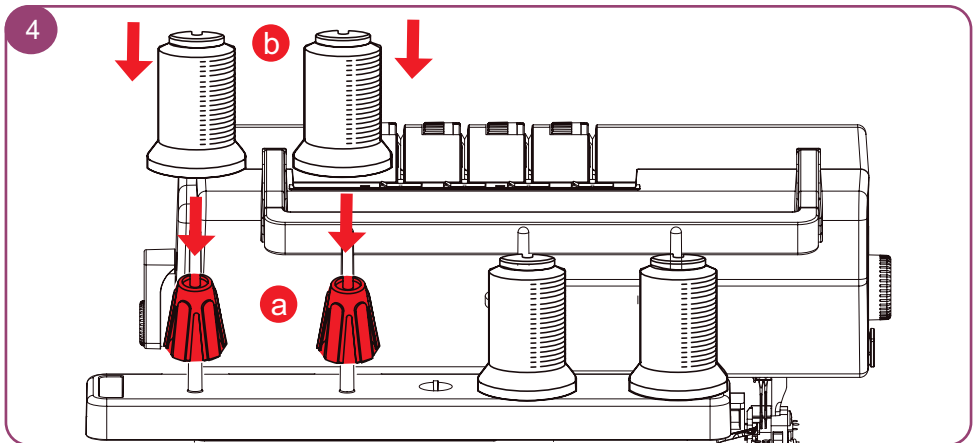
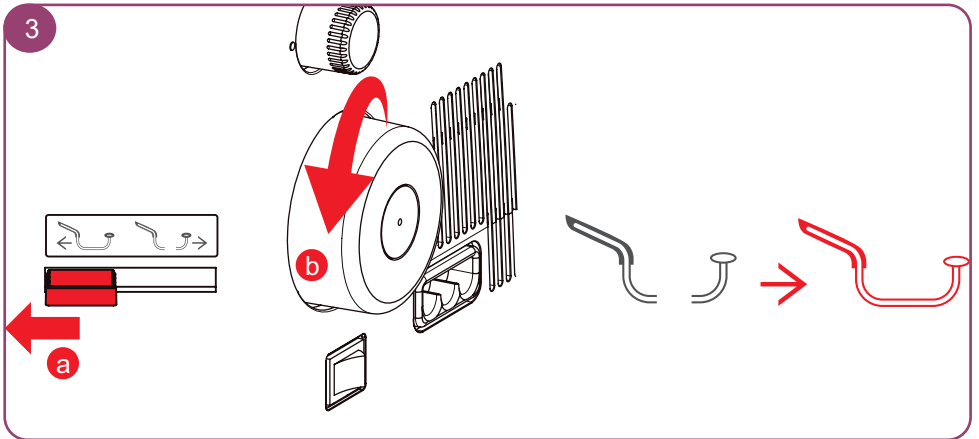
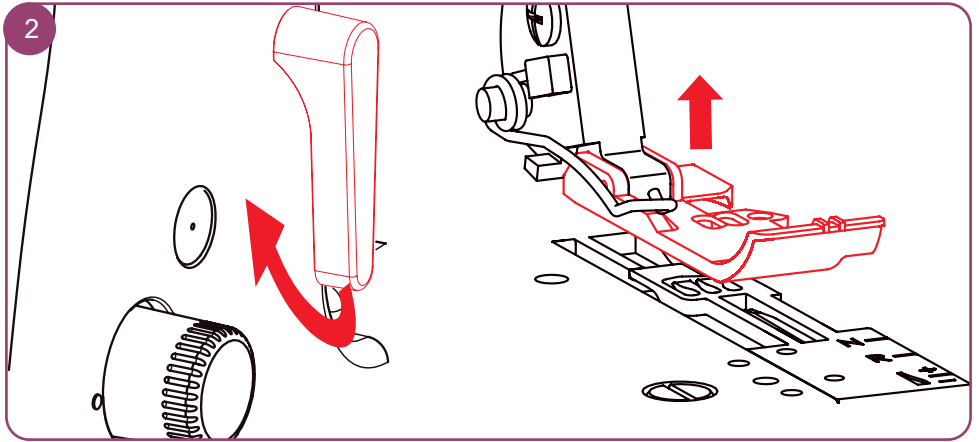

5

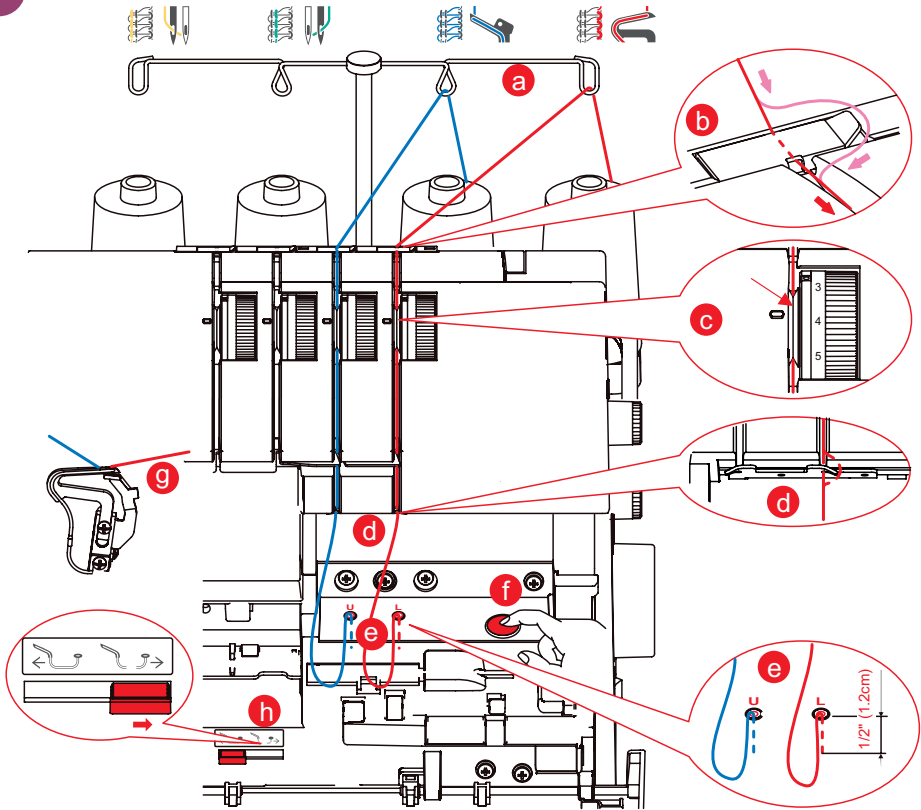

6

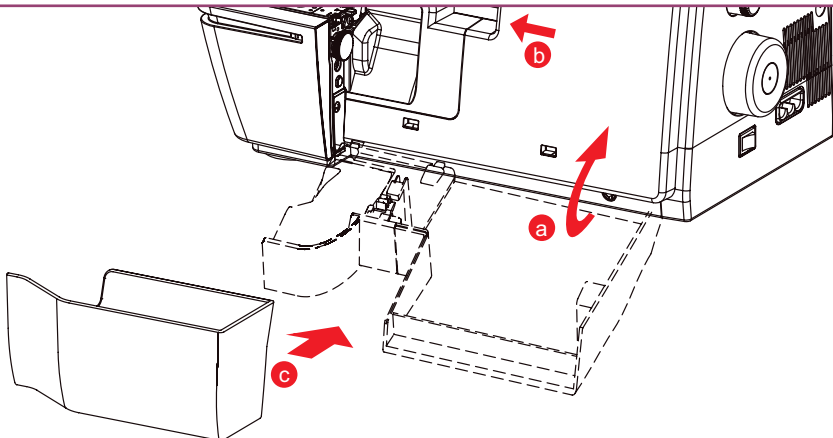

Threading the needle thread

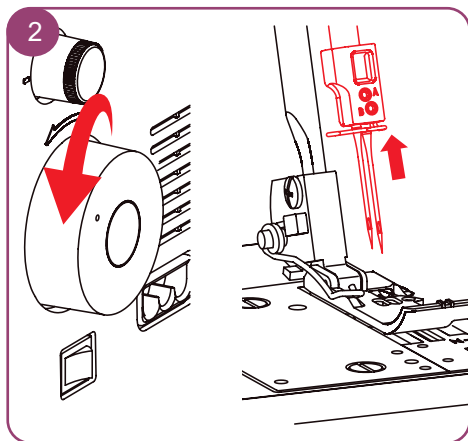
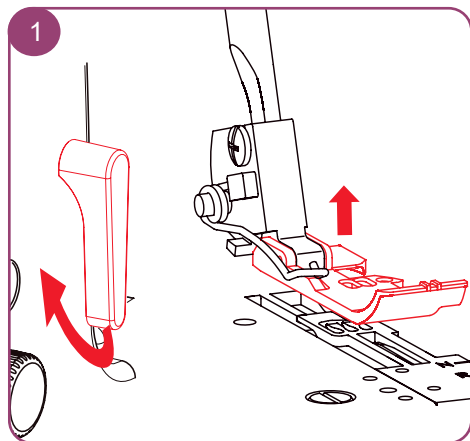

3

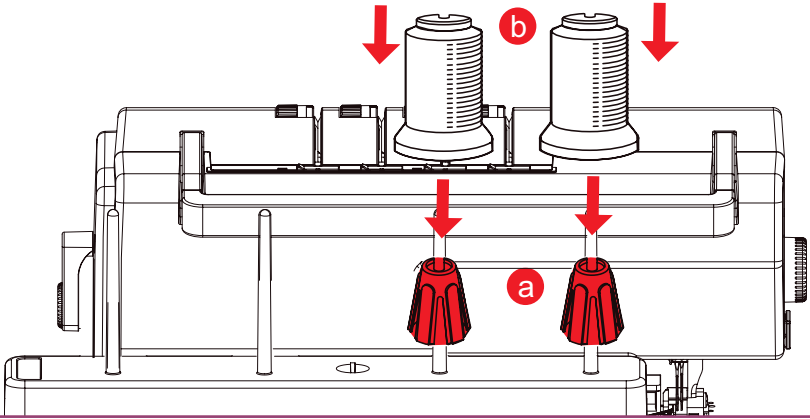

4

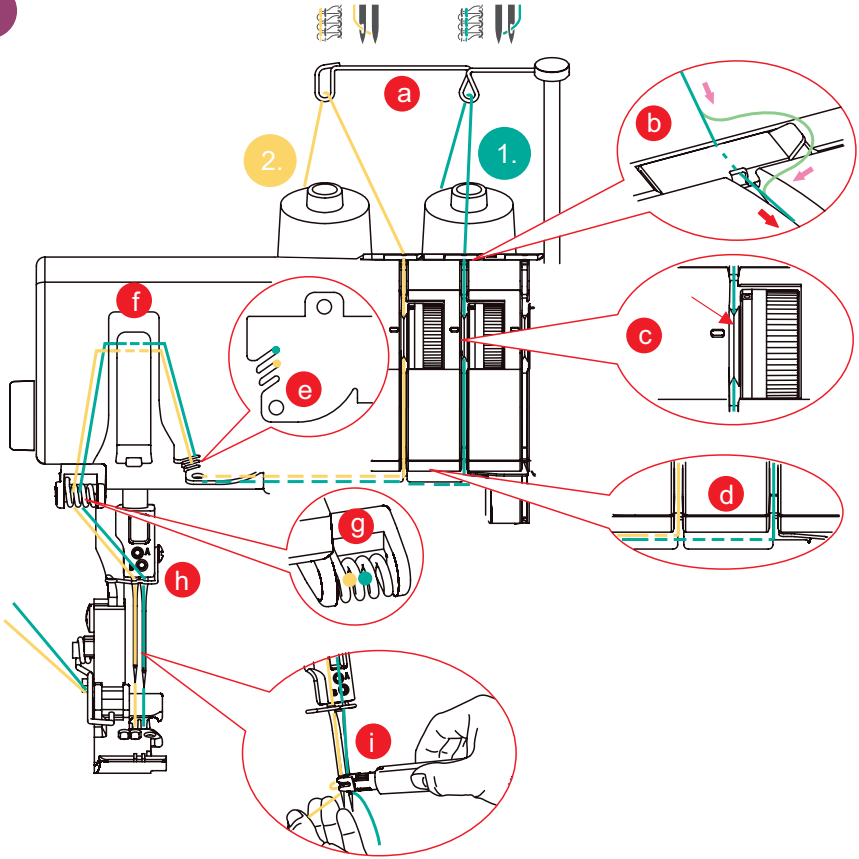

Adjusting the thread tensions

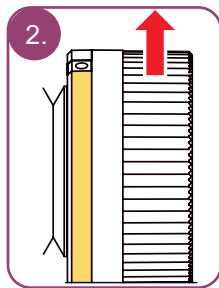
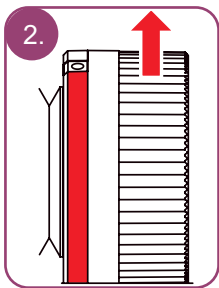
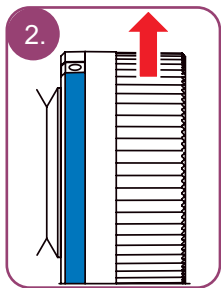
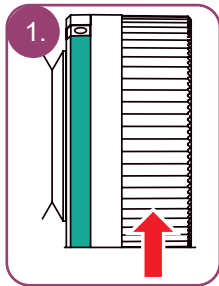
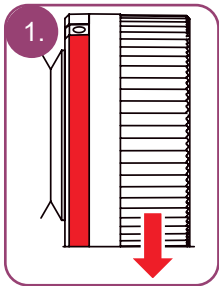
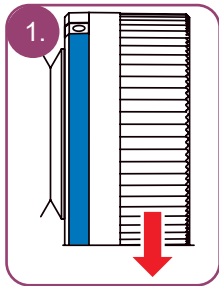
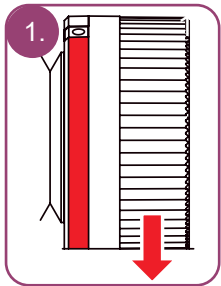
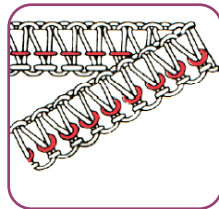
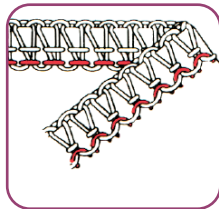
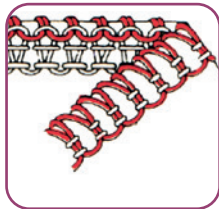
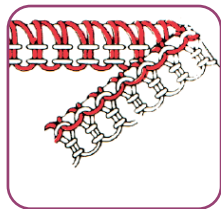

Setting the mtc micro thread control

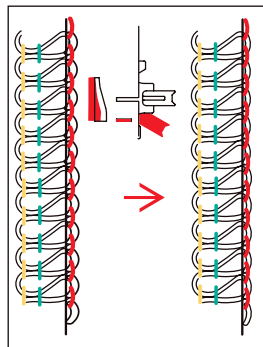
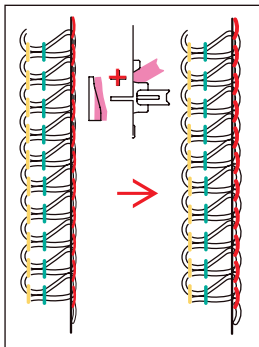
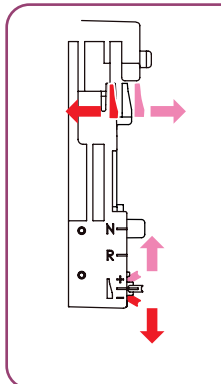

Setting the cutting width

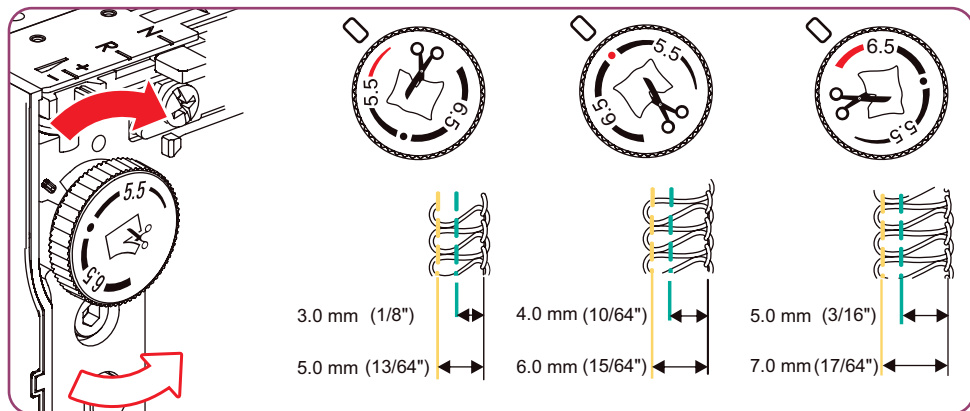

Setting the stitch length

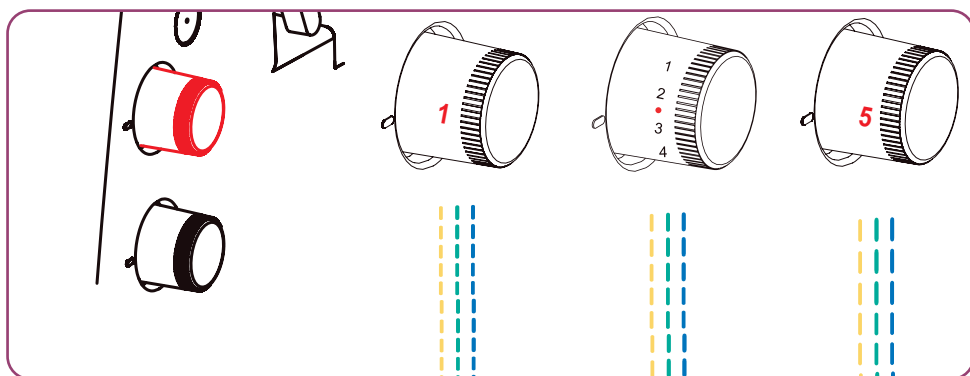

Adjusting the differential feed

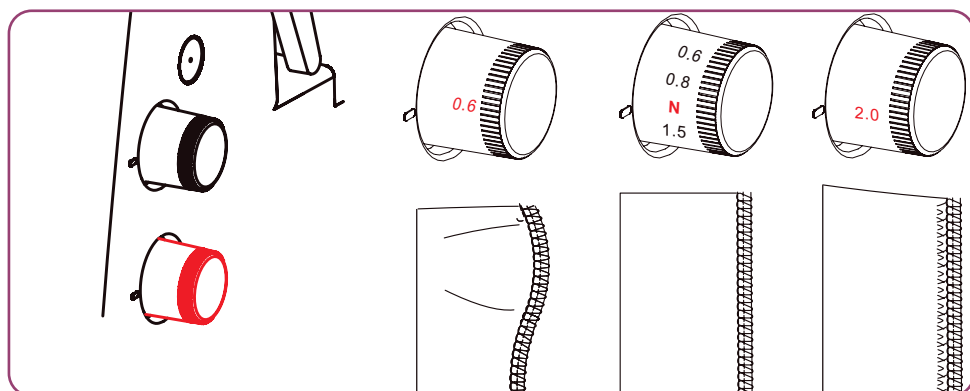

Cleaning and maintenance

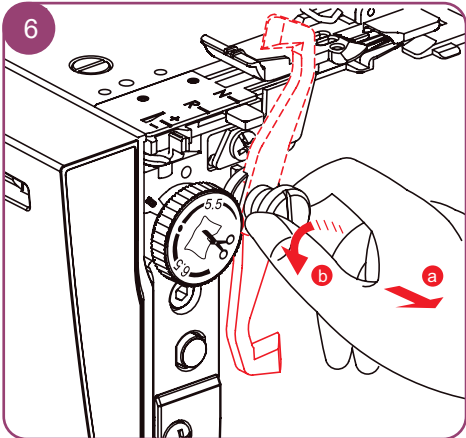
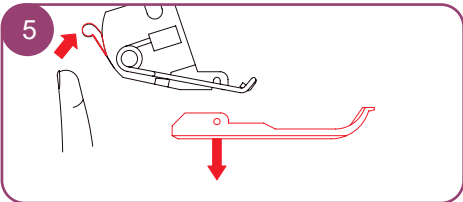
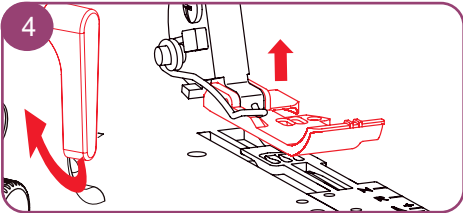
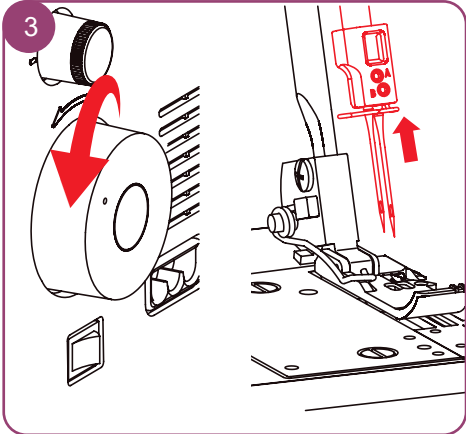
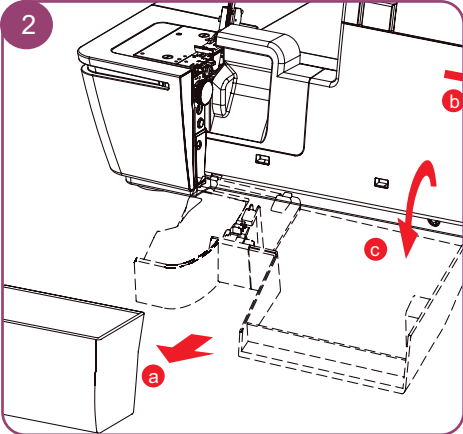
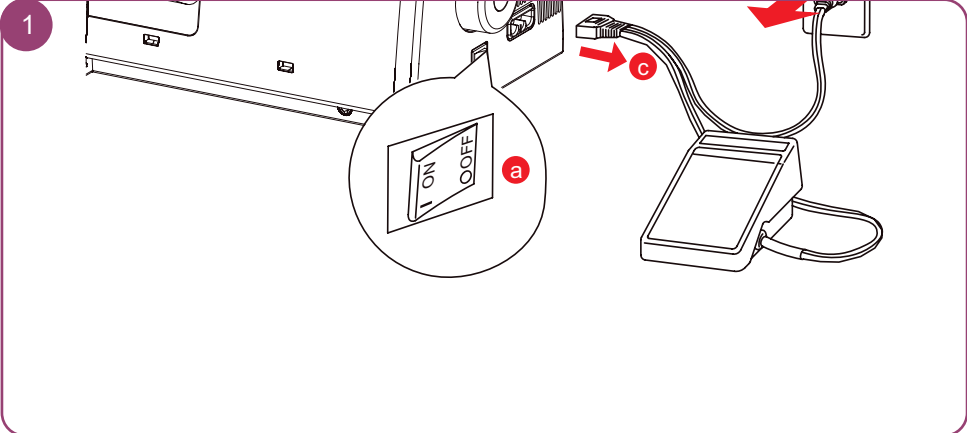

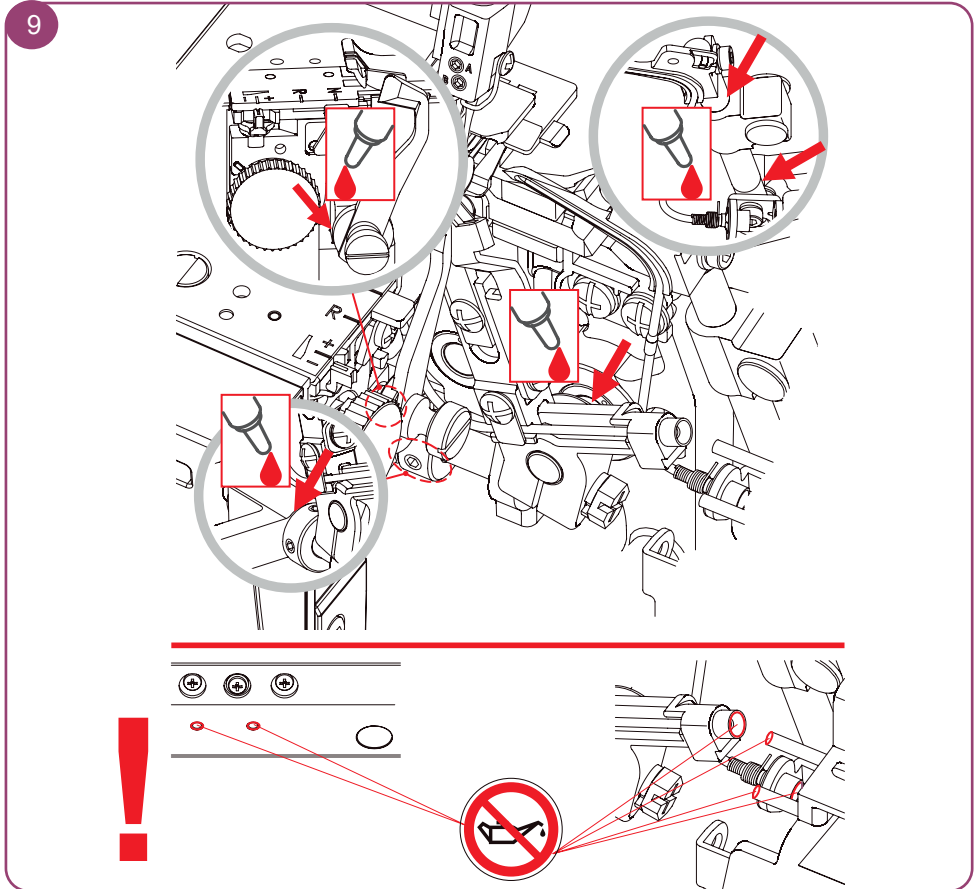
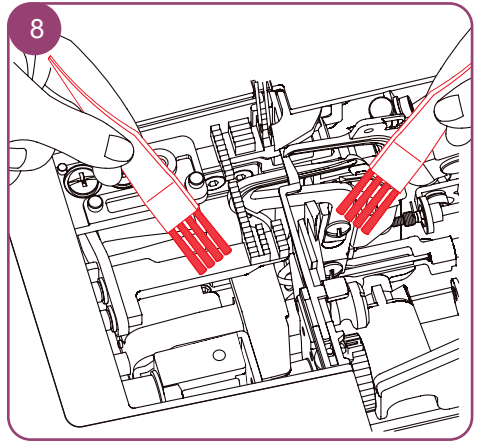
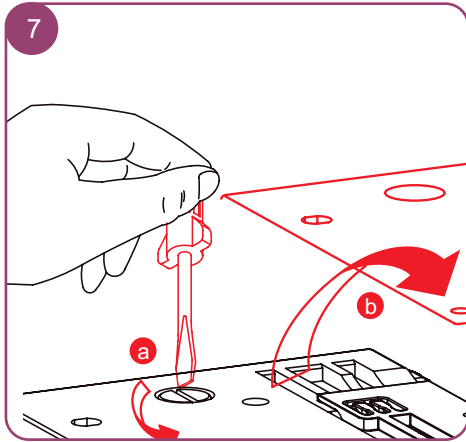

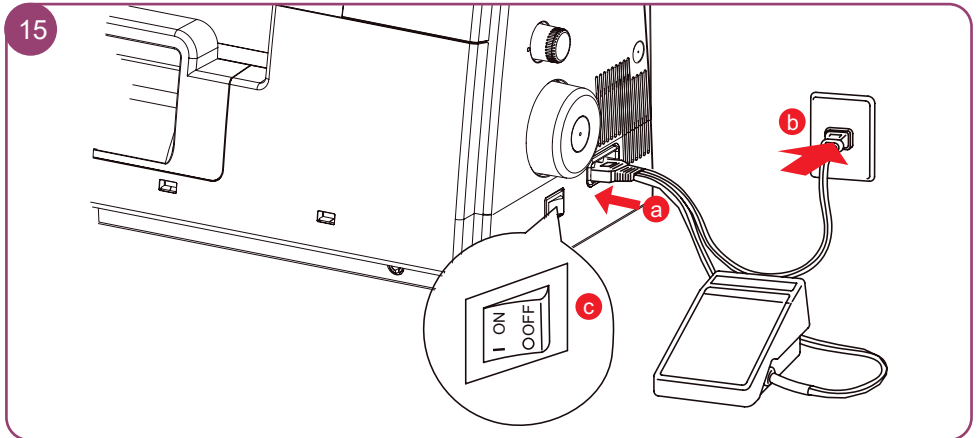
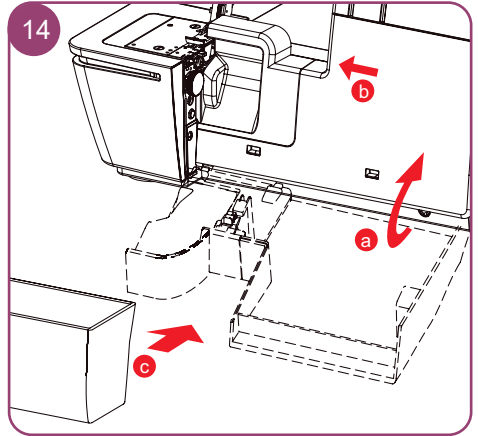
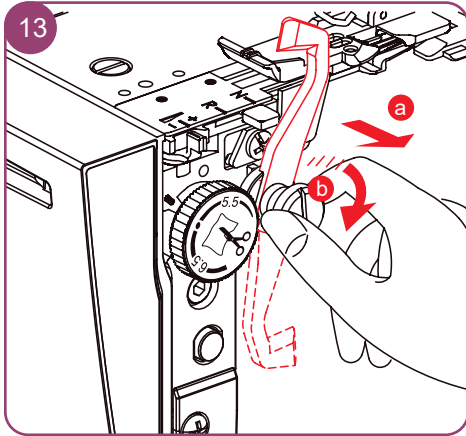
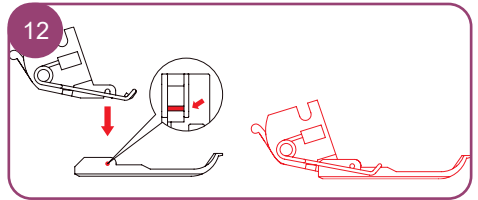
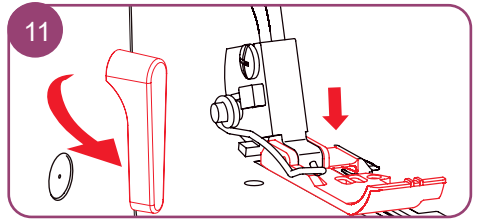
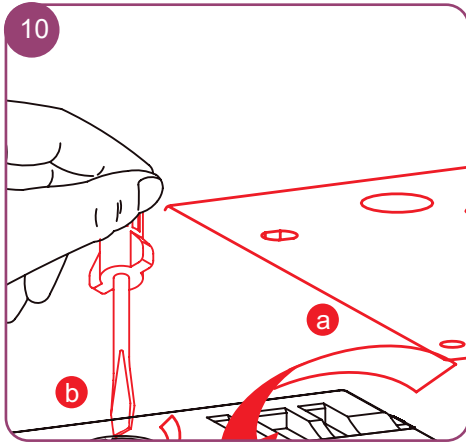

Troubleshooting

Fault	Remedy
Fabric does not feed well.	<ul style="list-style-type: none"> • Lengthen stitch length. • Increase presser foot pressure for heavy weight fabric. • Decrease presser foot pressure for light weight fabrics. • Check the setting of differential feed.
Needle breaks	<ul style="list-style-type: none"> • Insert needle correctly. • Do not pull fabric while sewing. • Tighten needle set screw. • Use a larger needle on heavy fabrics.
Thread breaks	<ul style="list-style-type: none"> • Loosen thread tension. • Check threading. • Check for tangled or caught thread. • Insert needle correctly. • Insert new needle; current needle may be bent or have a blunt point. • Use a high quality thread.
Skipped stitches	<ul style="list-style-type: none"> • Insert new needle; current needles may be bent or have a blunt point. • Tighten needle set screw. • Insert needles correctly. • Change type or size of needles. • Check threading. • Increase presser foot pressure. • Use a high quality thread.
Irregular stitches	<ul style="list-style-type: none"> • Balance thread tension. • Check for tangled or caught thread. • Check threading.
Fabric puckers	<ul style="list-style-type: none"> • Check the setting of differential feed. • Loosen thread tension. • Check for tangled or caught thread. • Use high quality weight thread. • Shorten stitch length. • Decrease presser foot pressure for light weight fabrics.
Irregular trimming	<ul style="list-style-type: none"> • Check alignment of knives. • Replace one or both knives.
Fabric piles up	<ul style="list-style-type: none"> • Lengthen stitch length. • Check the setting of differential feed. • Check for tangled or caught thread. • Compress thick layers of fabric with conventional machine before sewing with overlock.
Machine does not operate	<ul style="list-style-type: none"> • Connect machine to power source and switch it on. • Close the hook cover.

For complete instructions, you can link to the online user manual or how to videos www.bernette.com/b64AIRLOCK or scan the QR-Code with your smart phone.

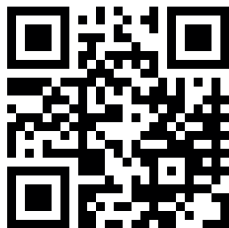

www.bernette.com/b64AIRLOCK

5400064.10A.04 - L2P08-02 | en 2023-06
© BERNINA International AG
Steckborn CH, www.bernina.com